

MODELS | BestStand 400 Series
BestStand 500 Series
BestStand 600 Series

OWNER'S MANUAL
AND INSTRUCTION GUIDE



**BestStand 500E shown*

**PRODUCT
FEATURES**

ASSEMBLY

**OPERATING
INSTRUCTIONS**

WARRANTY

BEFORE USE:



Ensure the product has been assembled according to the instructions in this manual.

All operators should have received or read and understood the instructions for safe and proper operation of the patient lift.

Thank you for choosing Bestcare!

To better serve you, please record
the following information:

Supplier Name: _____

Telephone: _____

Serial #: _____

Date of Purchase: _____

INSPECT YOUR MERCHANDISE

Upon receipt of your Bestcare Lift, verify that all merchandise is complete and free from any shipping damage. Refuse delivery if the packaging appears to be badly damaged. If the merchandise is received damaged or is missing components, contact the shipping company immediately and file a claim.

For further assistance, contact your local dealer or Bestcare LLC at the following:

Bestcare LLC
5885 Shiloh Rd., Suite 104
Alpharetta, GA 30005
678-679-6690 / 1-877-822-9033
www.bestcarellc.com
© 2013 Bestcare LLC

SAFETY INSTRUCTIONS



The BestStand Sit-To-Stand patient lift allows a caregiver to lift and transfer a patient safely with minimum physical effort. Before attempting to lift anyone, you should practice operating the lift and be able to explain to the patient the lifting and transfer procedures.

Arrange all necessary items (e.g. lift, sling, commode chair or wheelchair) properly for a smooth transfer.

- Special care must be taken with patients who are comatose, spastic, agitated, or otherwise severely handicapped. A competent caregiver must always be present during any patient lifting.
- The sole function of the patient lift is for transferring a patient from one utility (beds, bathtubs, toilets, etc.) to another.
- The lift should not be used to transport or move patients from room to room or over longer distances. Transfers should normally take place within the same patient room or bathroom.
- Do not put anything (e.g. cushion, pad, etc.) between the user and the sling. This may cause user to slide out of the sling and cause injury.
- The user/patient being transferred should be positioned in the center of the area being transferred from (i.e. bed, wheel chair, chair, commode, etc.) before being lifted, as well as when he/she is returned.
- Keep lifter base widened (use foot pedals to accomplish this) and brakes unlocked during lifting. If the brakes are locked during the lift process, the lift may become unstable.
- While the patient is suspended, always keep the patients centered between the base legs.
- Do not attempt to roll the lift or casters over floor obstacles while the user is in the sling and on board.

- Use only Bestcare slings specially designed and tested for Bestcare patient lifts . Do not use slings manufactured by other companies on Bestcare sit-to-stand patient lift. Bestcare LLC is not responsible for any consequence resulting from using non-Bestcare products.
- Use only Bestcare manufactured or approved parts and components. Bestcare LLC is not responsible for any adverse consequence resulting from using parts and components from other manufacturers.
- Service and repair of the patient lift should be performed by Bestcare or its authorized dealers **ONLY**. Bestcare LLC is not responsible for any consequence resulting from any unauthorized service or repair.
- Never attempt to lift over the maximum capacity of the lift and any accessories used in conjunction with the lift. The maximum safe working load for the lift will be clearly labeled on the lift.

DEFINITIONS & SYMBOLS

In this manual the user refers to the patient or resident and may be used interchangeably at different times. Caregiver refers to the operator or person who is assisting with the transfer.

Symbols used in this manual and their meanings:



Warning! Failure to heed this warning may result in damage to the product or serious injury to the operator and/or user.



Important instructions follow. Read and understand the instructions in the manual before using the product.



Note! Important information concerning the product and/or its correct and proper usage follows.

PRODUCT FEATURES

DESCRIPTION & APPLICATIONS

Bestcare presents the BestStand Series of sit-to-stand patient lifts, a solution for patient transfers between bed, chair or commode. The lift reduces injury risk associated with antiquated manual patient lifting practices. Competitively priced and combined with a unique design, the lift provides a new level of comfort and safety. The BestStand lift has set the standard for value and is an option for residential use.

- 400, 500, 600 Lb. safe working loads
- Low base
- Fully adjustable knee pad
- Removable foot platform
- Four sizes of deluxe padded slings
- Optional buttock support strap
- Knee pad strap for extra leg support
- Features alternative Sani-sling hook-up that eliminates underarm discomfort during transfer.

SPECIFICATIONS

& OPTIONS

CONTROL BOX

EL SERIES

E SERIES

Input Voltage	220-240VAC 50Hz / 110-120VAC 60Hz	220-240VAC 50Hz / 110-120VAC 60Hz
Output Voltage	24 VDC	24 VDC
Battery Pack	24 VDC 5AH	24 VDC 5AH
Control	Handset	Panel and Handset
Protection Class	IPxx	IP66
Over-duty alarm	by buzzer	by LCD
Battery Status	by LED color indicator	by LCD

PRODUCT FEATURES

	SA400 series	SA500 series	SA600 series
Maximum Safe Load Capacity	400 Lb.	500 Lb.	600 Lb.
Max. height of Boom	68"	68"	68"
Min. height of Boom	33"	33"	33"
Base closed external width	26"	25.5"	25.5"
Base open external width	38"	38"	38"
Base height clearance	4.7"	4.7"	4.7"
Overall length	40"	40"	40"
Boom Internal Width	19"	19"	19"
Bariatric Size Kneepad	Optional	Optional	Yes
Bariatric Size Footrest	Optional	Optional	Yes
Buttock Support Strap	Optional	Optional	Optional
Kneepad/Calf Support Strap	Optional	Optional	Optional
Quick Release	No	Yes	Yes
Dual Front Casters	No	Yes	Yes

**Bestcare is committed to continuous improvements of our products, therefore the specs, dimensions and features listed above are for guidance only and subject to change without prior notice.*

ASSEMBLY



Prior to assembly, unpack all parts from the shipping carton and check for any missing parts. Contact your dealer immediately if a part is missing.

Parts List for EL SERIES

1. Base
2. Mast
3. Control Box
4. Pendant
5. Actuator
6. Lifting Boom
7. Kneepad Assembly
8. Footrest
9. Castor with Brake
10. Front Castor

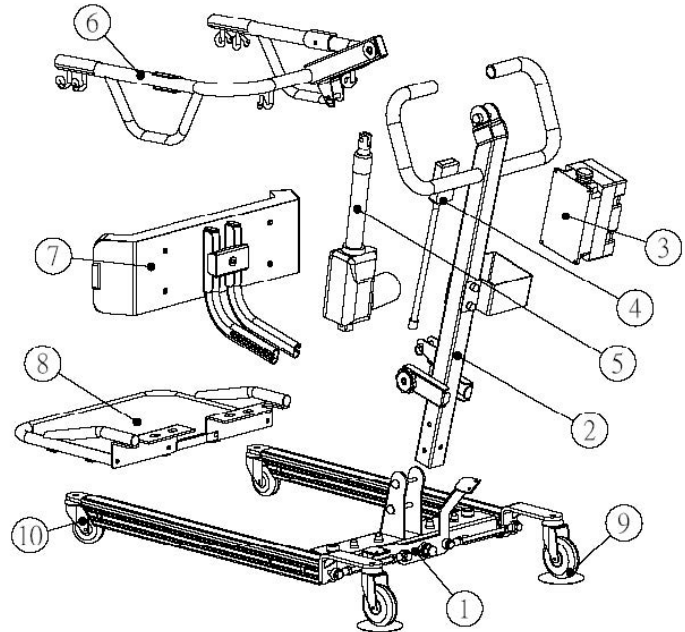

Parts List for E SERIES

1. Base
2. Mast
3. Control Box
4. Pendant
5. Actuator
6. Lifting Boom
7. Kneepad Assembly
8. Footrest
9. Castor with Brake
10. Front Castor

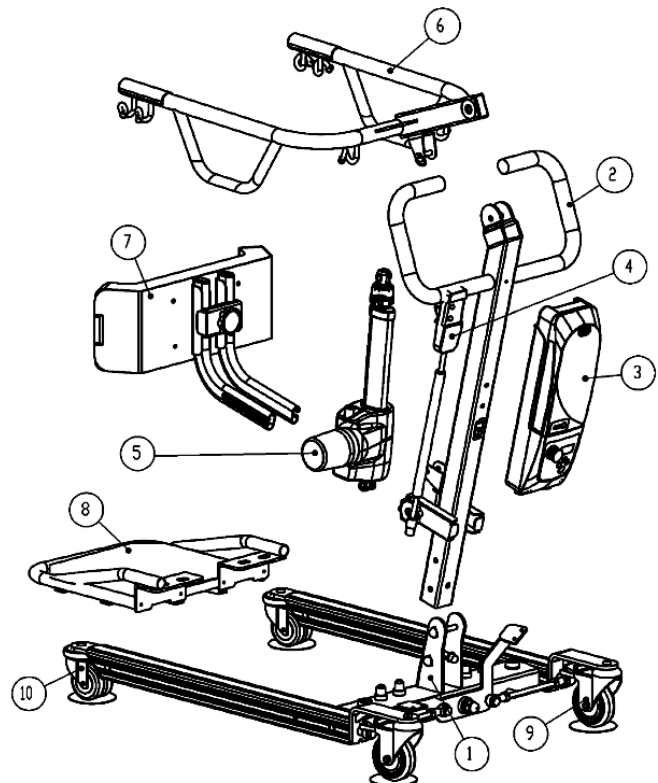

STEP BY STEP ASSEMBLY

1

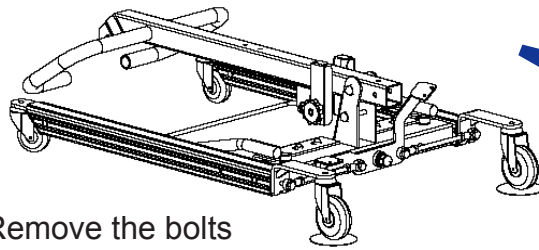

Engage the brakes. Remove the bolts from the bottom of the mast and base. Pull the mast to an upright position. Re-insert the bolts into the holes at bottom of the mast and tighten the nuts.

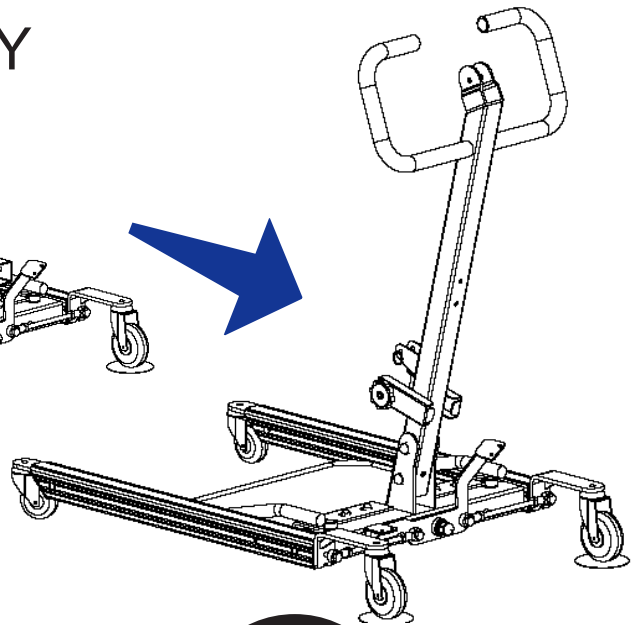

2

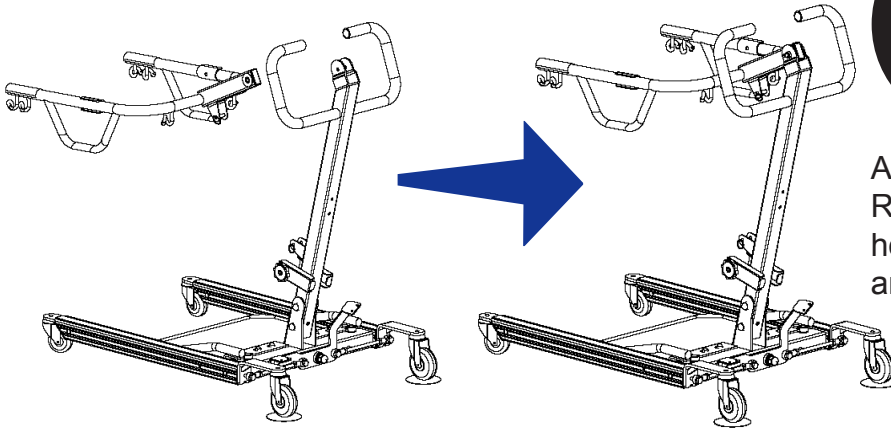

Attach boom to top of mast. Re-insert the bolts into the holes at bottom of the mast and tighten the nuts.

3

A. Attach the bottom actuator to the bracket on the mast and insert pin. Insert keeper ring through hole in pin to secure base of actuator.

B. Attach the top of the actuator to the bracket on the boom and insert pin. Insert keeper ring through hole in pin to secure actuator to upper bracket.

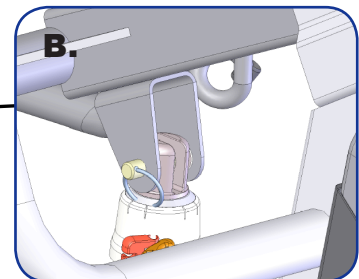
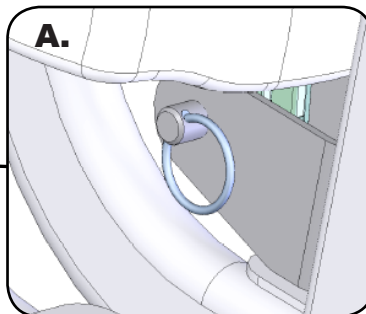
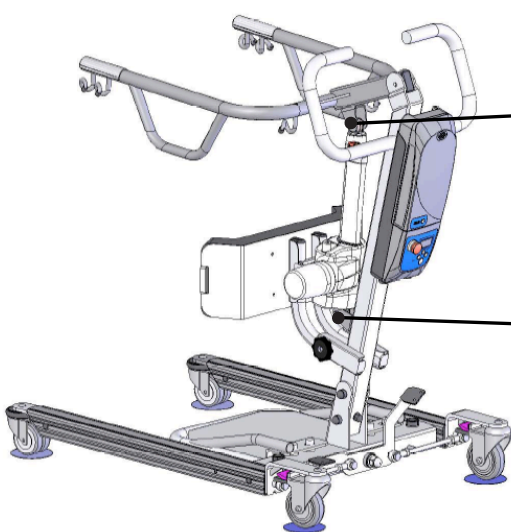

ASSEMBLY

4

KNEEPAD ASSEMBLY

A. Insert slotted bolt through bracket with washer on the outside and loosely attach threaded knob to the mast by turning the knob two times.

B. Slide “L” arm inside bracket with slotted bolt head inside the “L” arm then tighten to secure. Repeat these steps for the other side.

C. With both “L” arms securely attached to the mast, slide the kneepad onto the “L” arms and fasten into place with “U” bracket and knob bolt.

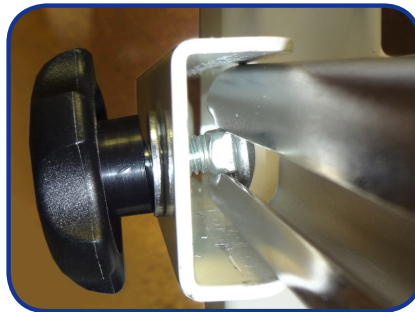

ASSEMBLY

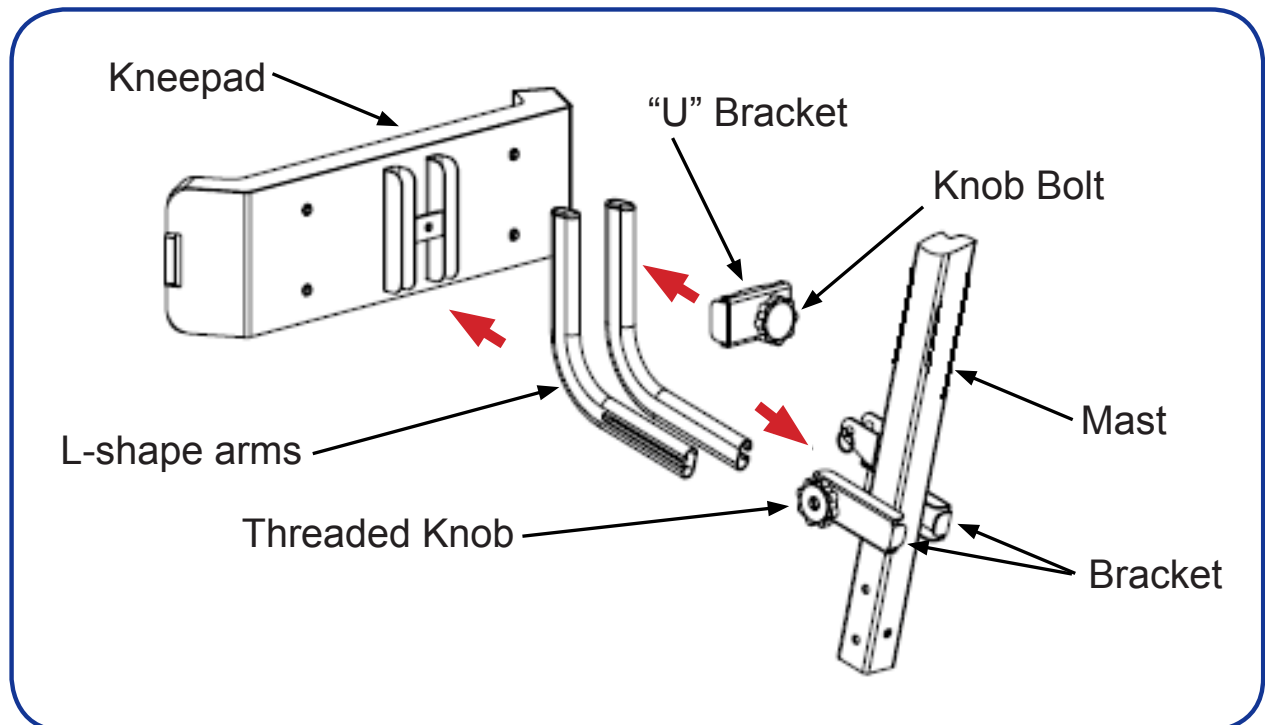

CONTROL BOX INSTALLATION

FOR PERFORMANCE SERIES

(for LEGACY electronic assembly see page 15)

Install the control box. Slide the control box over and onto the flat metal hook mounted at the bottom of the mast. Line up the control box with the hole at the top of the mast and insert the screw to hold the control box in place. Secure the control box by turning the lock mechanism into the lock position.

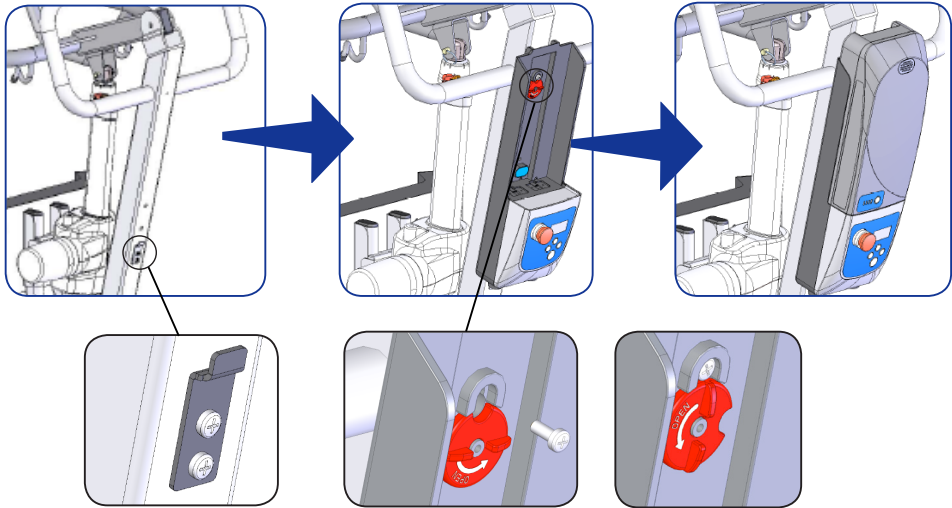

ASSEMBLY



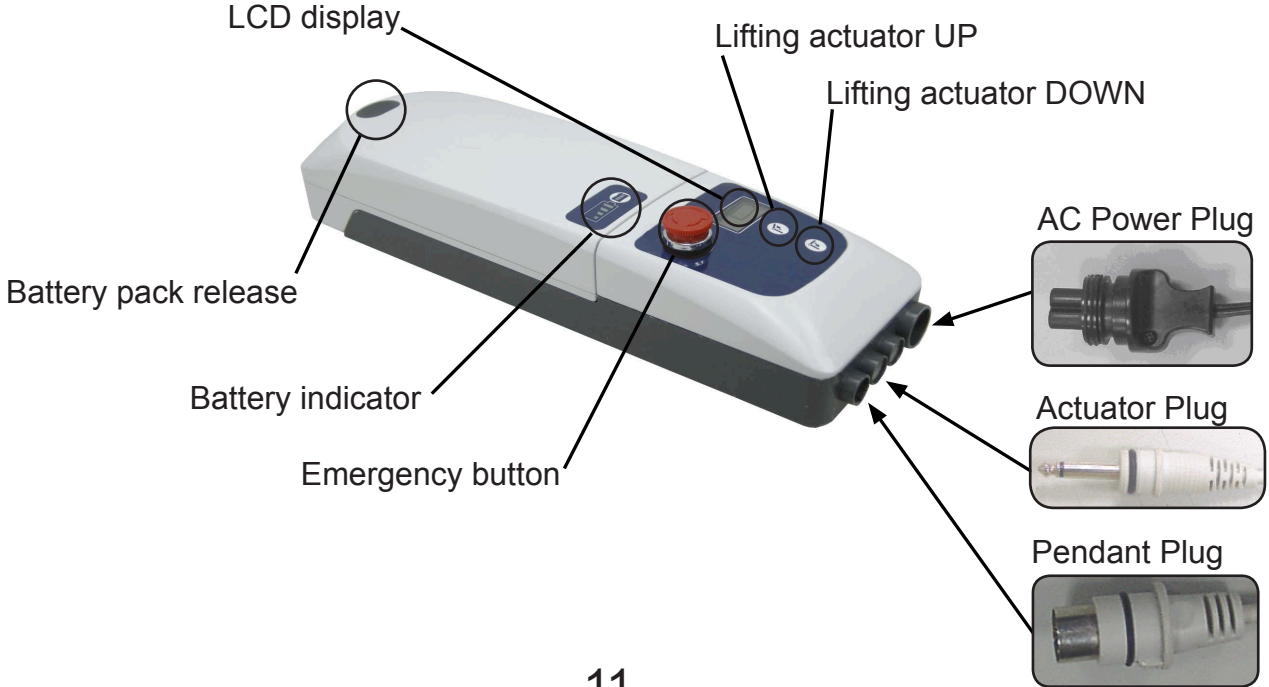

CONTROL BOX INSTRUCTIONS/PLUG-INS FOR PERFORMANCE SERIES









FEATURES:

- Smart charging function for longer battery life
- Battery capacity indicator on battery pack
- Soft start and stop for lifting actuator
- Soft and Hardware over-current protection
- Actuator's Over-duty protection with sign on LCD
- Emergency stop button interrupts the power supply to the actuator and makes the actuator stop immediately in case of sudden danger
- Internal charger
- LCD-display showing battery capacity and indication when the battery needs recharging.
- Audible alarm for low battery capacity
- Standard protection class: IP 66
- Pulling-proof design to lock the AC plug

LCD INDICATORS

	Low Batt.
	Overload
	Battery Volume
	Overused
low battery	Battery Low (Blink)

	Capacity	Function
	90%	Battery is charged to around 90%
	70%	Battery is charged to around 70
	50%	50% Battery Capacity Remaining Charge batteries immediately.
	25%	25% Battery Capacity Remaining Charge batteries immediately.
	10%	Battery is charged to around 10% Buzzer beeps / Only lowering possible
	0%	Power off

EMERGENCY STOP FOR PERFORMANCE ELECTRONICS ONLY

Emergency stop button interrupts the power supply to the actuators and makes the actuators stop immediately in case of sudden danger.

press RED button

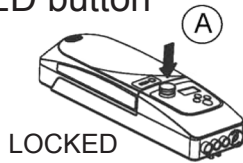

turn RED button clockwise

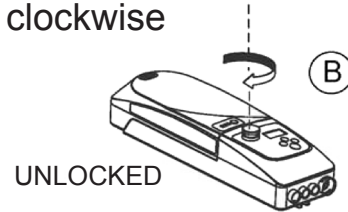

***IT'S STRONGLY RECOMMENDED THAT THE BUTTON IS PRESSED DOWN WHEN THE LIFT WILL NOT BE USED FOR OVER 3 DAYS TO MAINTAIN OPTIMAL BATTERY LIFE AND PERFORMANCE.**

FEATURES OF POWER PLUG:

C-CLAMP :

- when the battery is being charged, insert this C-clamp to secure the power plug

WATERPROOF COVER:

- when control is not being used, the cover should be closed to prevent water ingress.

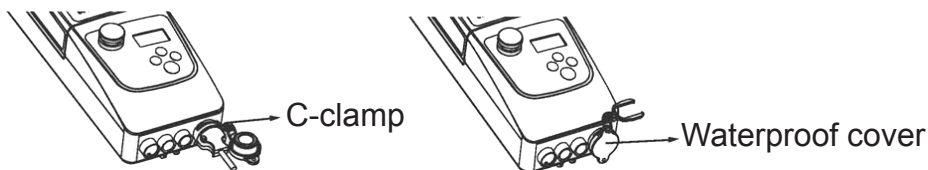

REMOVE AND INSERT BATTERY PACK:

REMOVE : press button A and pull out in the up direction (Fig.1)

- INSERT:
- Insert the battery pack into control box as show in Fig. 2 & 3.
 - While pressing the release/latch button **A**, slide the battery pack into control box in the downward direction and ensure battery pack latch hooks onto the top of the control box.
 - Once the battery pack is hooked onto the control box, release button **A**.

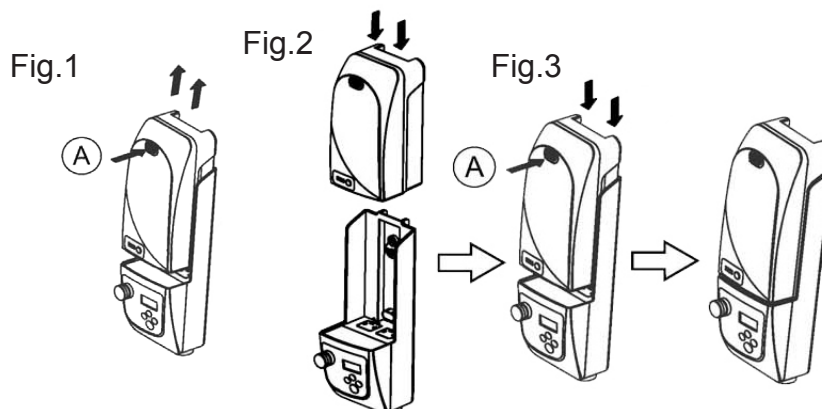

FOR PERFORMANCE E-D SERIES

(extra wall-mount charger and battery pack)

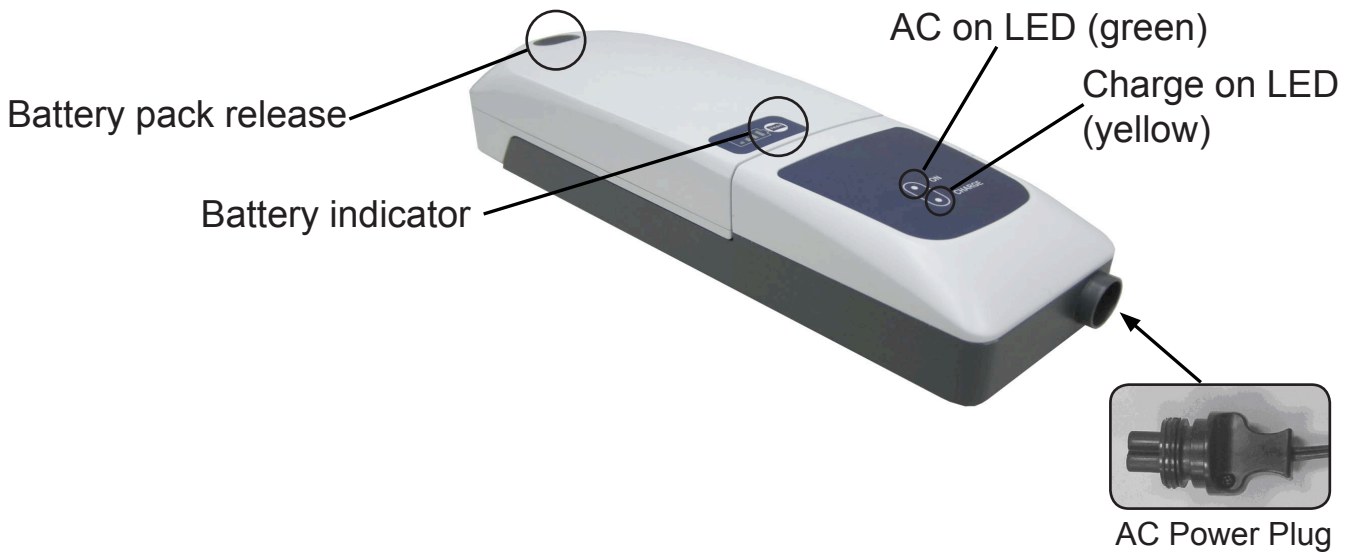

ASSEMBLY

Step 1: Install two mounting bolts (M5 or gauge 10 having at least 8mm head) onto the mounting surface that are 12.4 in. / 31.6cm apart as shown in **Fig. A**.

Step 2: Turn the lock mechanism to the unlocked position **Fig.B**.

Step 3A: Hook the charging unit onto the mounting surface by first sliding the bottom slot over the bottom screw.

Step 3B: Align and fasten the top hole to the top screw.

*you may have to adjust the bolts for a tight and flush fit with the mounting surface.

Step 4: Lock the charging unit securely in place as shown in **Fig. C**.

TO REMOVE AND INSERT BATTERY PACK PLEASE SEE PAGE 13. FOLLOW INSTRUCTIONS TO REMOVE AND INSERT BATTERY PACK FROM CONTROL BOX.

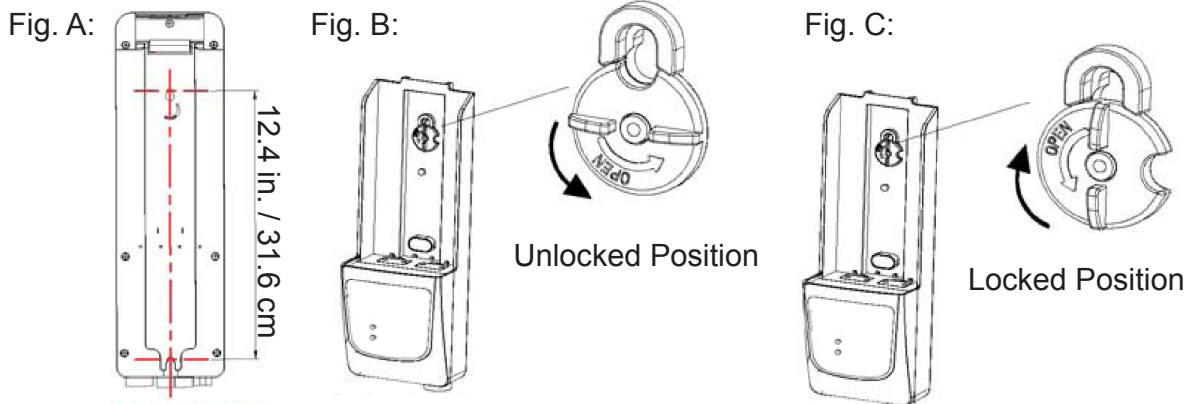

FOR LEGACY SERIES

(for PERFORMANCE electronics assembly see page 11)

Attach the Control Box Hanging Bracket to the Mast and tighten the nuts. Once the bracket is secure, then place the Legacy Electronic Box inside.

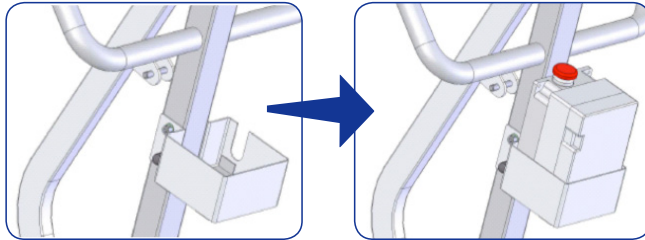

CONTROL BOX INSTRUCTIONS/PLUG-INS

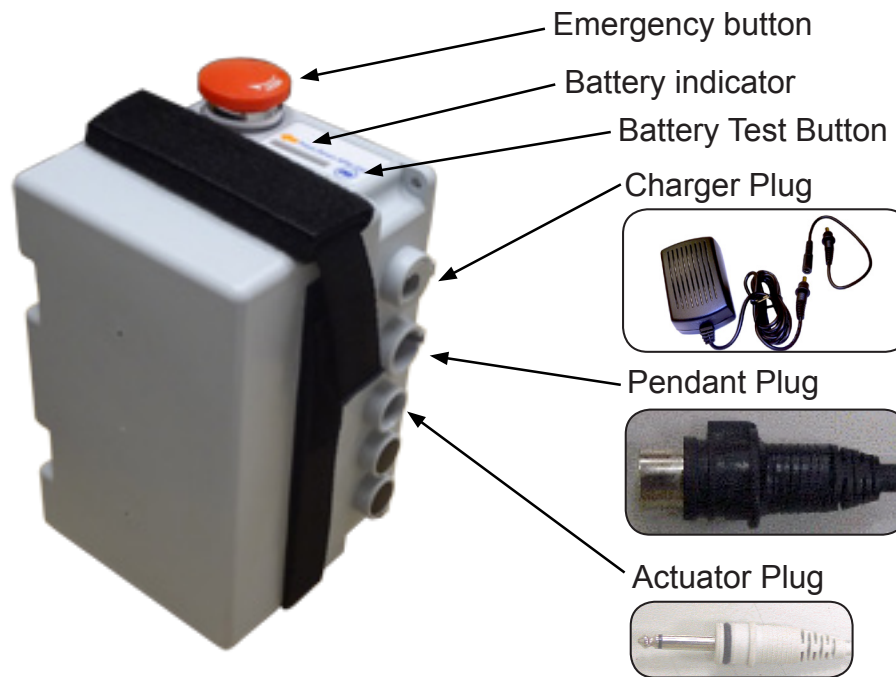

ASSEMBLY

CHECKING THE BATTERY:

- Check batteries by pressing the Battery Testing Button (blue circle with a battery sign) on the control box.
- Batteries are fully charged when all lights on the Battery Indicator are "ON".
- Charge batteries when Indicator shows only one "GREEN" light.
- Do not use the lift when no "GREEN" light is shown. Charge the batteries immediately.
- Replace batteries when frequent charging is needed.



PATIENT LIFT WILL NOT OPERATE WHILE CHARGING

CHARGING THE BATTERY

- Ensure the power is switched “ON” (the red “RESET” button should be up).
- Insert charging plug into charging port on the control box.
- Plug charger to power supply.
- All lights of battery indicator should be “ON” while charging.
- It takes approximately 2-3 hours to fully charge the batteries from one green light.
- It takes approximately 7-9 hours to fully charge the batteries from the red light.
- Do not charge the batteries for an extensive period of time. This will shorten the life of the batteries.
- Do not let the batteries run down to the last red light. This might shorten the life of the batteries or damage the batteries.
- Unplug the charger first before using the lift.

KNOW WHAT YOUR BATTERY IS TELLING YOU

RED	AMBER	GREEN	GREEN	GREEN	
ON	ON	ON	ON	ON	FULLY CHARGED
ON	ON	ON	OFF	OFF	NEED CHARGE
ON	ON / OFF	OFF	OFF	OFF	CHARGE IMMEDIATELY. DON'T USE THE LIFT
OFF	OFF	OFF	OFF	OFF	BAD BATTERIES OR BAD CONNECTION

WARNING BUZZERS

The control box has a buzzer that provides you with information on the status of the batteries and the lift. To stop the buzzer, push down the RESET button or press the Battery Test button.

BUZZER TYPE	INDICATION	NOTE
2 beeps/sec	Low Battery (red/amber lights on)	Charge batteries immediately.
3 beeps/sec	Low Battery (red light on)	Charge batteries immediately.
6 beeps/sec	Very Low Battery (no light on)	Charge batteries immediately.
3 beeps every other second	Bad Battery (no light on)	Replace batteries.
3 long beeps	Overloaded. Batteries are charged but lift does not lift.	Exceeded maximum load capacity.

IMPORTANT NOTES ON CHARGING

- Push lift to charging location and charge the batteries with the charger provided. Avoid unplugging the hand control and motor from control box. Frequent plug/unplug of the hand control and motor into/from the control box may damage the control box.
- Do not charge batteries over 12 hours.

OPERATING INSTRUCTIONS



Double check all assemblies for tightness and read operating instructions carefully prior to use.

Do not attempt to use patient lift unless the patient exhibits control over the upper body, strength to grasp the handles, ability to bear some weight and flexibility in knees, hips and ankles.



PREPARATION BEFORE LIFTING

- Turn on the power by twisting the RED RESET BUTTON clockwise
- Press the UP or DOWN button on the hand control once and check if the battery indicator lights are on.
- Position the base of the lift around or under the object
- Widen the base and engage the caster brakes



Do not attempt to transfer a patient without prior approval of the person's nurse. Also, do not transfer without having studied the instructions and performed several practices in operating the product. Together with the patient's doctor, nurse or medical attendant, select a sling that is both practical and comfortable. The sling selected should be one that serves the needs of the patient, while providing the patient with optimal safety. Never interfere with the lift unless instructed by the attendant. Have a doctor, nurse, or medical attendant (experienced in the use of the BestStand Lift) present during the first few times the lift is used to transfer a new user.

FITTING STAND ASSIST SLING

- Position the patient in a sitting position
- Slide the sling down patient's back to lumbar position.
- Draw the shoulder straps to the front of the patient close to the chest.
- Draw the waist belt around patient's waist and press together to fasten.

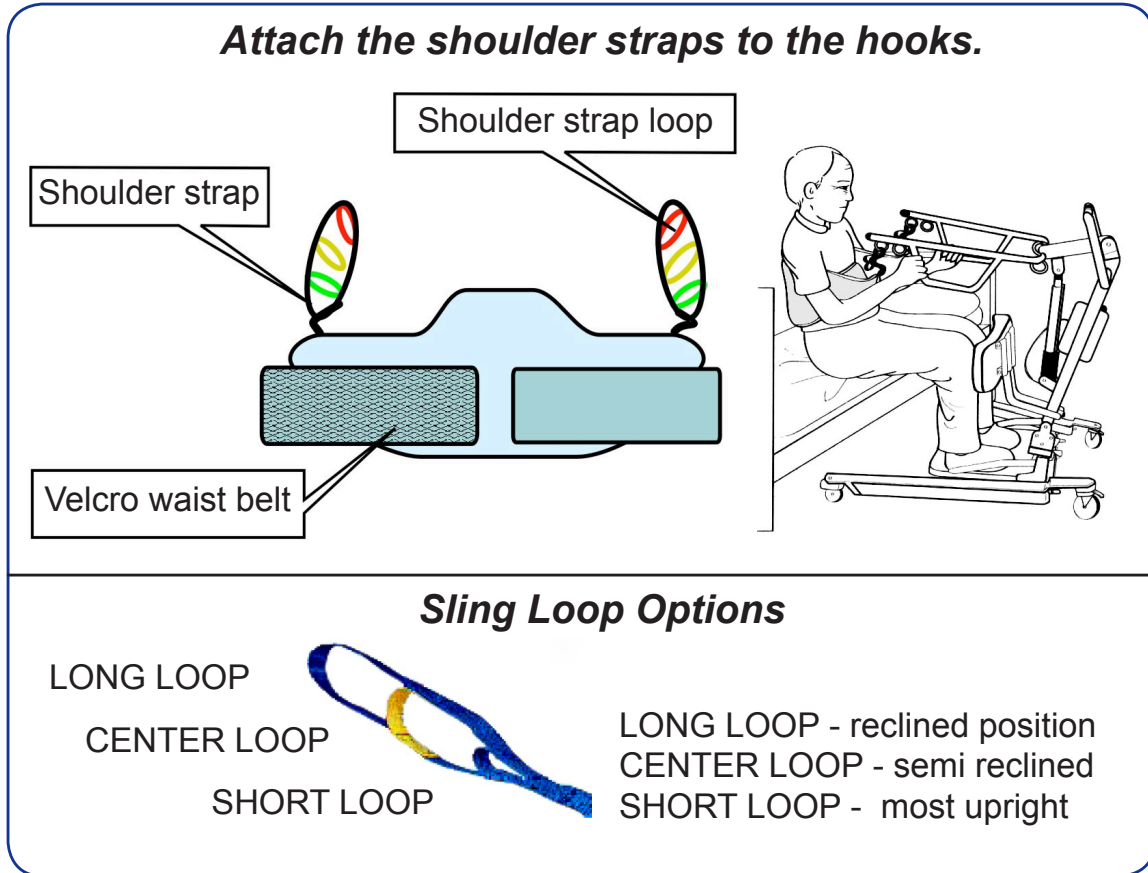

OR

For sling application

- Place sling behind seated patient with the 2 red pads under the arms.
- Cross the adjustable chest belt over and fasten it securely using the buckle (adjust for comfort).
- Cross the short black strap over and pull the left loop strap through the black strap.
- Hook the two loop straps to the hooks on the lift boom using the same hook and loop sequence on each side.
- The black strap will be straight across in front of patient to stabilize the sling during lift.
- Have patient grasp handles on boom and tilt head back slightly.
- Make sure the patients feet are firmly on the platform and knees are touching the kneepads with kneecaps just above the padding.
- Use the lift to complete the lift and pivot transfer.

FITTING SUPPORT STRAP

DIAGRAM 1

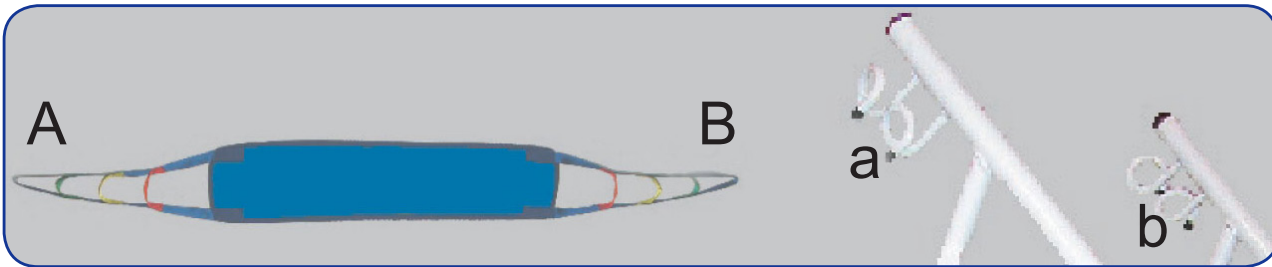

DIAGRAM 2



DIAGRAM 3



- Check sling weight capacity for the patient being lifted. Do not exceed maximum safe working load.
- Review following procedures carefully prior to attempting lift. Call with any questions.
- Position the sling around the buttocks of the patient. This sling is designed to support the middle and lower part of the body.
- Attach the sling strap to the lower “pig tail” “A” on the mast of the Stand Assist lift as in Diagram 1. Bringing the other side around the back of the patients’ buttocks (to fit like a park swing) and attach lower “pig tail” “B”.
- Position sling so it gives the greatest support to middle and lower part of the patient being lifted.
- Notice, in Diagram 2, that the Buttock strap MUST be used with the Stand Assist sling. These slings are designed to compliment one another in providing the greatest comfort and security for the patient being transferred.
- Push lift towards patient. Open the base of the lift. Apply the brakes in both rear casters.
- Proceed with lift and transfer as in Diagram 3.

LIFTING HINTS

- Prior to beginning a lift have the patient lean slightly back and look at a 45 degree angle to the ceiling; this help position the sling; this is recommended only at the start of a lift
- Try the sling straps in various color positions to establish best fit
- Always insure the same color straps on each side are attached to lift
- Should patients have a larger girth in mid section or back side area try the optional buttock strap to help with initial lift leverage
- Remember this lift is designed for pivot transfers and it is not necessary to lift to full upright position; as long as the patients body clears bed or chair and vice versa you can move the lift and place patient in new position.



It is not uncommon for the strap to loosen and drop down as lift proceeds.

LIFT AND TRANSFER FROM BED

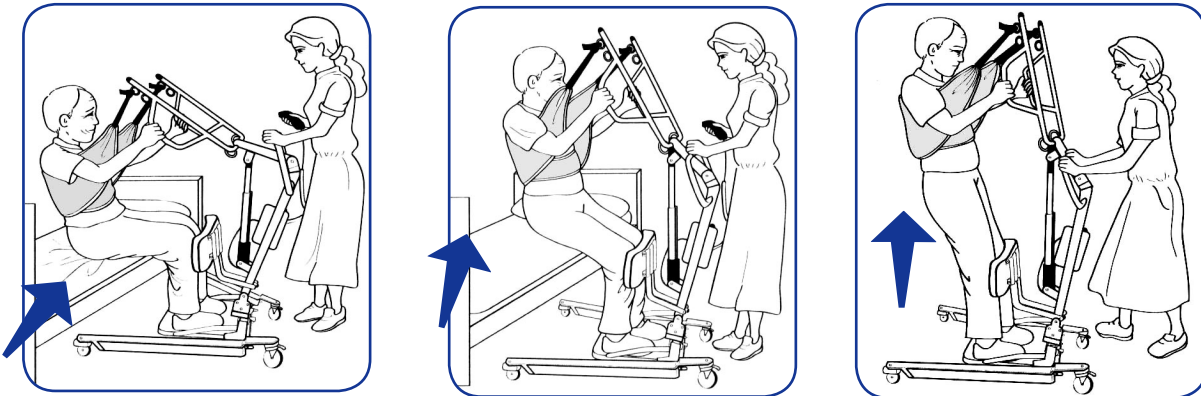

- Fit sling as described in “Fitting Bestcare Stand Assist Sling”.
- Push lift towards patient. Open the base of the lift. Apply the brakes in both rear casters.
- Position patient’s feet on the foot platform and knees against the knee pad.
- Attached the sling straps to the hooks.
- Have the patient’s hands holding the handles. For patients who cannot hold the handles, have them hold their arms around the chest.
- Press the “UP” button on the hand control.
- Before the patient’s body has lifted from the bed, stop and make sure the sling is secured and patient’s knees are against the knee pad.
- The patient should be comfortable with the pressure under the arms. If not, adjust the sling and try another loop option to release pressure.
- Press the “UP” button until the patient’s body has completely left the bed.
- Transfer to another object can be done at this position without the patient attending a full standing position.
- Release the brakes, close the base, and pull the lift away from the bed.
- Lower the patient to the object intended.
- To lift patient in a standing position, continue to lift until the patient’s knees are locked in a standing position.
- At the standing position, patient’s knees may move away from the knee pad.
- Release the brakes, close the base, and pull the lift away from the bed.
- Lower the patient to the object intended.
- Reverse the above procedures when lowering the patient to the object intended.

LIFT AND TRANSFER FROM CHAIR

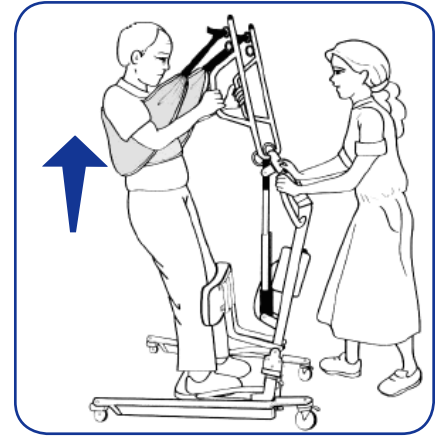
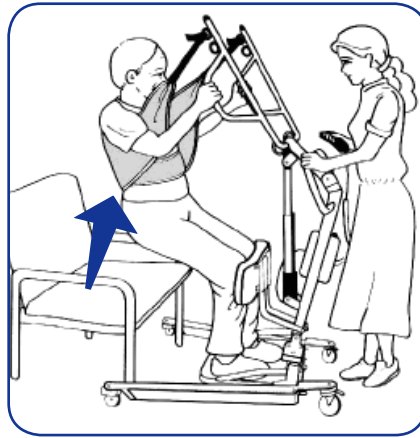
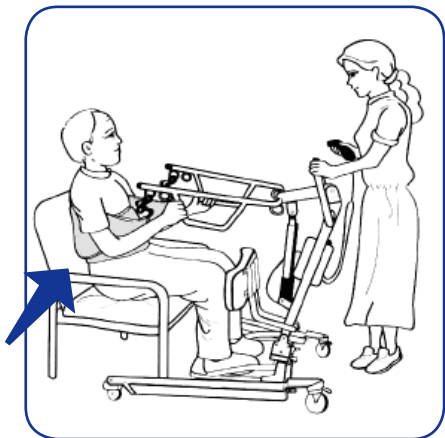

- Fit sling as described in “Fitting Bestcare Stand Assist Sling”.
- Push lift towards patient. Open the base of the lift to go around the chair. Apply the brakes in both rear casters.
- Position patient’s feet on the foot platform and knees against the knee pad.
- Attached the sling straps to the hooks.
- Have the patient’s hands holding the handles. For patients who cannot hold the handles, have them hold their arms around the chest.
- Press the “UP” button on the hand control.
- Before the patient’s body is lifted from the chair, stop and make sure the sling is secured and patient’s knees are against the knee pad.
- The patient should be comfortable with the pressure under the arms. If not, adjust the sling and try another loop option to release pressure.
- Press the “UP” button until the patient’s body has completely left the chair.
- Transfer to another object can be done at this position without the patient attending a full standing position.
- Release the brakes, close the base, and pull the lift away from the chair.
- Lower the patient to the object intended.
- To lift patient in a standing position, continue to lift until the patient’s knees are locked in a standing position.
- At the standing position, patient’s knees may move away from the knee pad.
- Release the brakes, close the base, and pull the lift away from the chair.
- Lower the patient to the object intended.
- Reverse the above procedures when lowering the patient to the object intended.

LIFT AND TRANSFER FROM COMMODE

BESTCARE TOILETING SLING

The BestCare Toileting Sling can be used with the BestStand to lift a patient in a sitting position. When in use the BestStand Toileting Sling supports the client under the thighs and across the mid-back area.

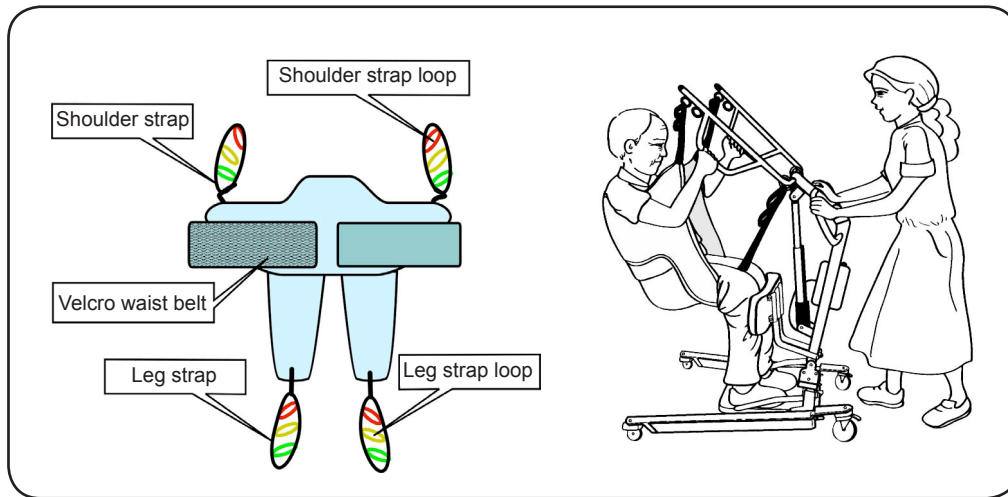

The Bestcare Toileting Sling is not suitable for patients who have involuntary movements or patients with limited postural control.

OPERATING INSTRUCTIONS

Fitting the BestCare Toileting Sling

- Slide the sling down patient's back to lumbar position.
- Draw shoulder straps under the arms and around the chest into the front.
- Draw Velcro waist belt around waist and press together to fasten.
- Draw each leg support under the thigh.
- Crisscross leg straps by feeding one of the leg straps through the other strap.
- Attach shoulder straps to hooks in upper ends of the lifting arms.
- Attach leg straps to hooks in the lower ends of the lifting arm.

MAINTENANCE & INSPECTION



The operator of the lift shall inspect the BestStand Lift before each use. Check all bolts for tightness. Make sure the base can be easily widened and that all lift parts are in place. Make sure that casters can be turned freely, and that caster brakes can be engaged. Make certain all necessary items (i.e. slings, wheelchairs, etc.) are ready for use.

At least once a month, the lift should be thoroughly inspected by a person qualified to recognize any signs of wear and tear and looseness of bolts or parts. Replace any worn parts immediately.

To lubricate, put a drop of oil on the following points when the BestStand Lift is placed into service and every month thereafter: Top of Mast, Spreader Hinge, and Caster Axles.

	FIRST RECEIVED	MONTHLY	EVERY 3 MONTHS
BOOM & SPREADER BAR			
Check connections between Boom and Mast for improper connection, looseness or wear.	●	●	
Check the Boom for bending and deflection.		●	
MAST			
Check the Mast for bending or deflection.	●	●	
BASE & FOOT PEDAL			
Check bolts and nuts for looseness.	●	●	
Check casters and axle bolts for tightness.	●	●	
Check rubber parts on the casters for deflection	●		●

	FIRST RECEIVED	MONTHLY	EVERY 3 MONTHS
BASE & FOOT PEDAL			
Apply grease to caster ball bearings if needed.			●
Check welding joints for rust and crack.		●	●
CLEANING			
AS NEEDED			
ACTUATOR & CONTROL BOX			
Make sure the control box is firmly affixed to the mast.	●	●	
Make sure the actuator is secured to the boom and mast with pins and key rings	●	●	
Make sure actuator plug into control box is not loose.	●	●	
SLINGS & SLING HARDWARE			
Check sling for wear.	●	●	
Check sling hardware every time before use.	●	●	

TROUBLESHOOTING GUIDE

The following list of encountered problems and solutions will assist you in determining what may be causing your patient lift not to function as designed. If you have a problem occurring which is not listed below, please contact your dealer or technical support for help. Do not attempt to repair or replace components or parts on your lift as this may void your warranty or cause further problems that may result in patient injury. Stop using your lift immediately if it is not functioning correctly or any warning beeps are heard.

I need to re-charge my batteries often or they fail to hold a charge when I charge them.

- Replace the batteries or battery pack as they are at the end of their life cycle
- Batteries should be changed every 18-24 months depending on usage

The actuator will either go up or down but not both

- Replace your hand control as it is at the end of its life cycle
- Your control box may be malfunctioning

There is a grinding sound inside the actuator when lifting

- Replace your actuator as the internal gears are stripped

The actuator stops and starts while lifting or lowering

- Replace the batteries or battery pack as they are at the end of their life cycle

My lift will not operate even though it shows the batteries are charged

- Unplug the AC power cord from the control box as the lift will not work when the control box/charger is connected to AC Power
- Check to make sure the hand control is properly inserted all the way into the control box port
- Check to make sure the actuator plug is properly connected and inserted all the way into the control box
- Your hand control needs to be replaced as it is at the end of its life cycle

If there is a problem you cannot correct, please contact your dealer for assistance.

EMERGENCY LOWERING MECHANISM



The following instructions apply to BestStand 500 & 600 **series ONLY**

In case there is a failure with the actuator or electronics and the user is left suspended in mid-air, please follow the procedures below to safely lower the user to a safer position.

The Quick Release mechanism is activated by the RED lever mounted at the top end of the actuator. Activate the Quick Release by pulling the RED lever with the arrow symbol in the direction indicated by the arrow. This will de-clutch the actuator and safely lower the user down.

NOTE! When the Quick Release is activated, the boom will not lower itself unless there is sufficient weight or force applied in the downward direction.

Contact your dealer immediately if standard troubleshooting techniques do not correct the failure. Do not attempt to lift until all failure and safety issues have been resolved.

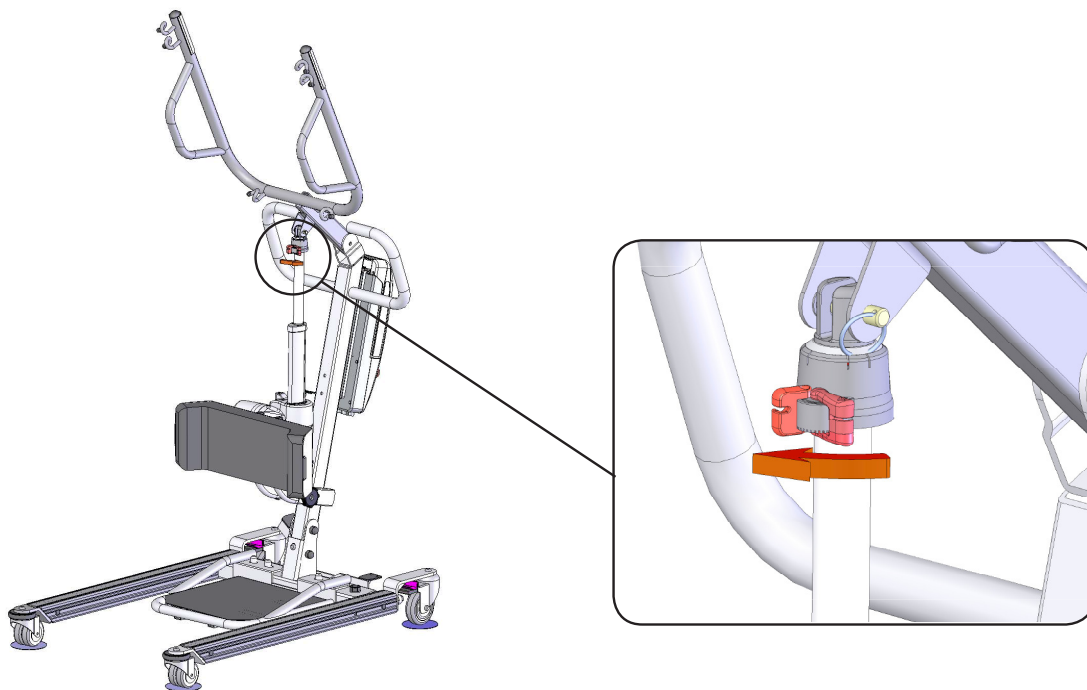

NOTE: THE EMERGENCY LOWERING DEVICE IS INTENDED FOR USE DURING LIFT FAILURE. THIS DEVICE WILL ALLOW LOWERING OF PATIENTS ONLY. PLEASE CONTACT YOUR DEALER IMMEDIATELY IN CASE OF FAILURE.

BESTCARE LLC WARRANTY AND RETURN GOODS POLICY

Bestcare LLC offers a limited warranty on all patient lifts, slings and accessories to be free of defects in workmanship and product performance. This warranty is extended only to the original purchaser/user and is therefore non transferrable. Any warranty claims must be submitted through an authorized dealer or distributor that sold the original product with proper proof of sale and serial number supplied. Prior authorization from Bestcare LLC is required for any warranty replacement and we reserve the right to replace parts and or accessories in lieu of sending complete new patient lifts. Dealers and distributors will be billed for any advance warranty replacement items shipped and credited at 100% only when the defective items have been returned to Bestcare LLC and proven defective. Product returned without a Bestcare LLC return authorization will be refused. Returns received 30 days after the issuance of a return authorization will also be refused as the authorization will have expired. The final disposition of warranty claims will be subject to our inspection of the returned items. Bestcare LLC has the right to determine valid claims based on the individual circumstances of each claim. Warranty claims will be denied should evidence of the following be determined:

- Misuse of product , modification of product or failure to maintain as per the owner's manual
- Serial number removed or defaced
- Normal wear and tear

Bestcare LLC warrants the following products and components for the time period specified:

- Lift frames and spreader bar: 3 years
- Actuator: 2 years
- Parts including casters, control box, PCB, pendant, charger: 2 years
- Batteries: 1 year
- Weigh Scale: 2 years
- Spryte Stand Aid all components: 2 years
- Hydraulic pumps: 1 year
- Reusable slings: 6 months

Bestcare LLC Single Patient Slings are designed for limited use with one patient and may not be washed. Bestcare will replace any disposable slings found to have a manufacturing defect. Normal wear and tear will not be covered under warranty.

RETURN GOODS POLICY:

Bestcare LLC will allow goods to be returned only with prior authorization and a valid RA number issued by the RA co-coordinator. RA's will only be provided for items invoiced within 30 days of the initial RA request. All returns must be received at Bestcare LLC within 30 days or the RA will expire. The returning package must be clearly marked with the RA number or the shipment will not be received or any credit issued. When a part is returned to Bestcare LLC for warranty inspection a \$50 service charge will apply if the part is not defective. Returns are subject to a minimum re-stocking fee of 15% or more depending on the condition of the returned items. Where an item was ordered incorrectly according to your purchase order or the customer no longer wants the item(s) returning freight is the responsibility of the dealer/customer not Bestcare LLC.

Patient lifts may not be returned unless the following has occurred:

- The wrong lift was shipped in error by Bestcare LLC
- The lift is heavily damaged or defective out of the box

Please note that lifts being returned must be in the original carton and all parts and components included with the return. Failure to comply with this requirement will incur higher re-stocking fees or a rejection of the return. Slings, parts and accessories may only be returned if they have not been used. There are no exceptions to this provision. Bestcare LLC reserves the right to issue credit amounts based on strict adherence to this policy.

Bestcare **L.L.C.**

Bestcare LLC
5885 Shiloh Road Suite 104
Alpharetta, GA 30005
tel. 678-679-6690
free 1-877-822-9033